

DIGITAL TAPE EXTENSOMETER

EXTENSOMETERS
& JOINTMETERS

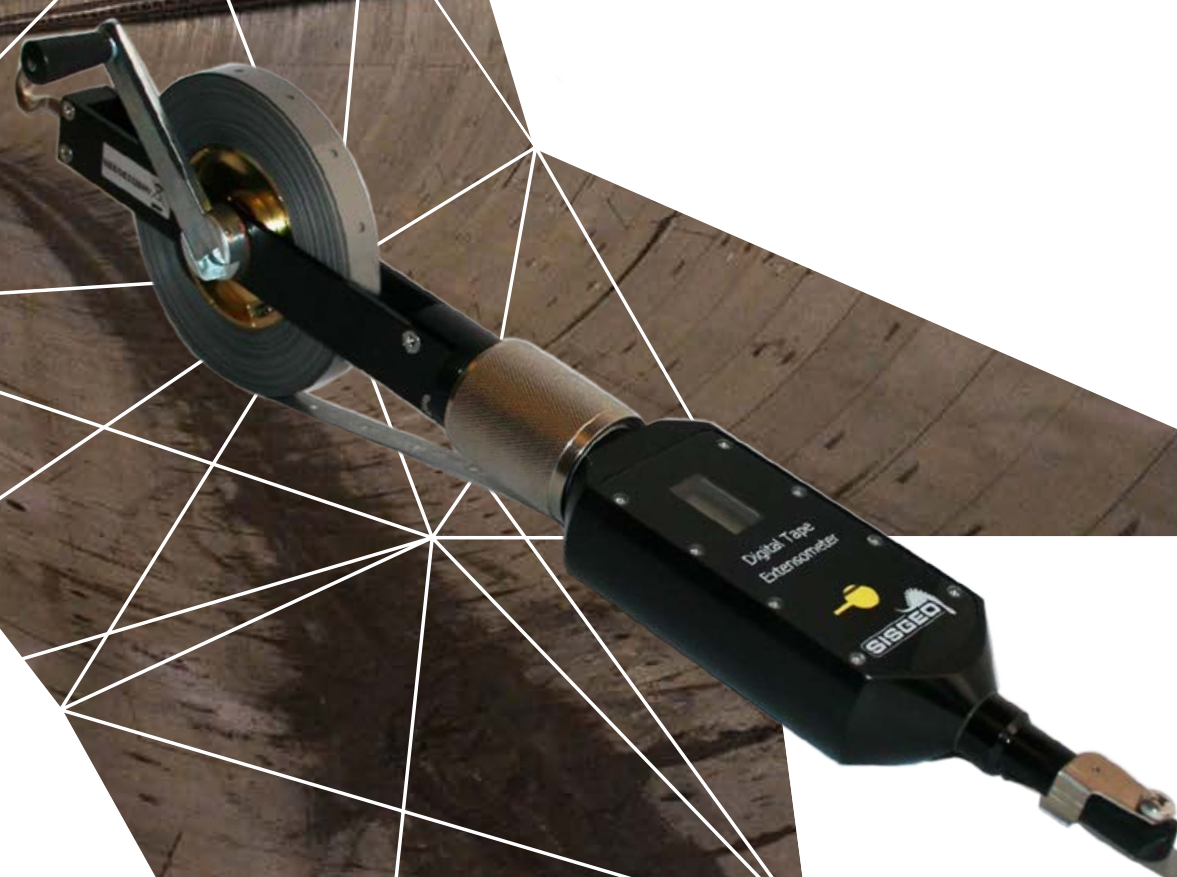



DIGITAL TAPE EXTENSOMETER

Tape extensometer is designed to take accurate distance measurements between pairs of reference points permanently installed.

Tape extensometer is equipped with stainless steel measuring tape with equally spaced punched holes incorporated in a rugged body with digital dial gauge. Available with both hook or 3/8" threaded terminals.

Typical applications include convergence measurements of tunnel linings, according to NATM practice, and monitoring of shafts, underground openings and caverns.

APPLICATIONS

- Convergence measurements in tunnels according to NATM practice
- Displacements in underground excavations and mining
- Monitoring of rock masses
- Rotation / displacement of retaining walls

FEATURES

- Portable and lightweight
- Read relative pin distances up to 30 m
- Optical tension indicator grants repeatable readings
- Robust construction



Meet the essential requirements of the EMC Directive 2004/108/EC

TECHNICAL SPECIFICATIONS

PRODUCT CODES	0DN0030D000	0DN0030D380
Tape lengths	30 M tape	30 M tape
Terminals	hook terminals	thread terminals
Material	stainless steel	stainless steel
Hole pitch	25 mm	25 mm
Accuracy of the micrometer	±0.01mm	±0.01mm
Resolution of the micrometer	0.01 mm	0.01 mm
Operating temperature	-10 +60 °C	-10 +60 °C
Tape Tension	11 kg	11 kg
Tension Indicator	Optical	Optical
Power Off	Automatic	Automatic
Power On	Automatic (upon movement of the micrometer)	Automatic (upon movement of the micrometer)

PHYSICAL FEATURES

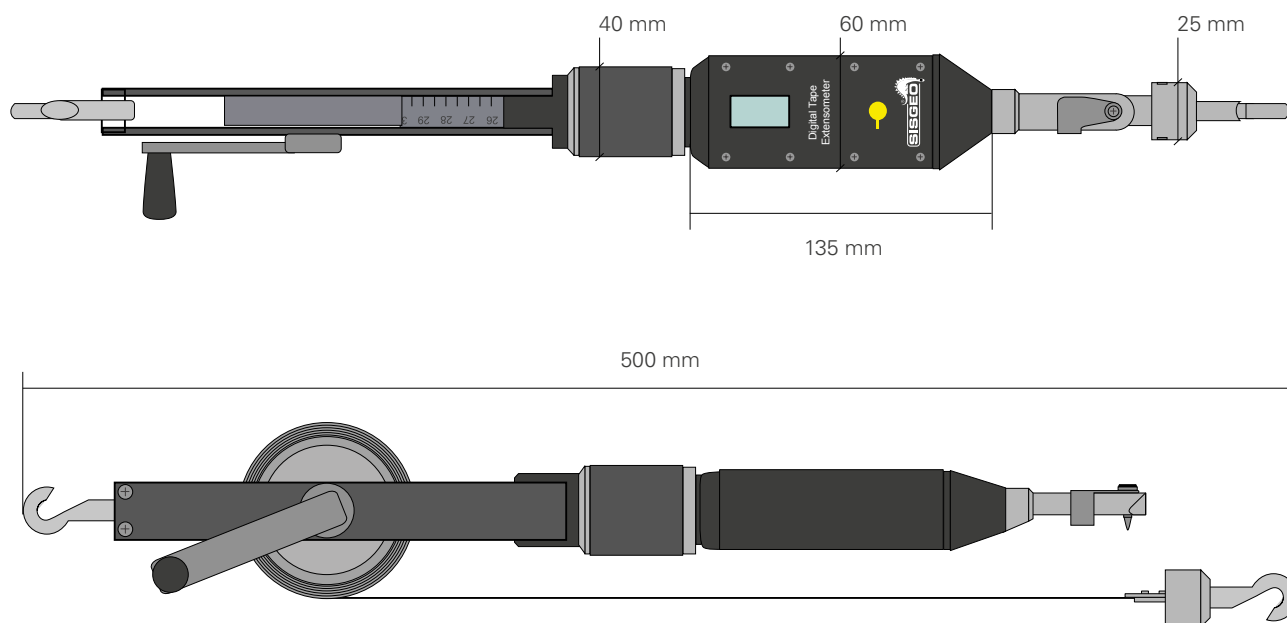

APPLICATION IN TUNNEL CONVERGENCE MONITORING

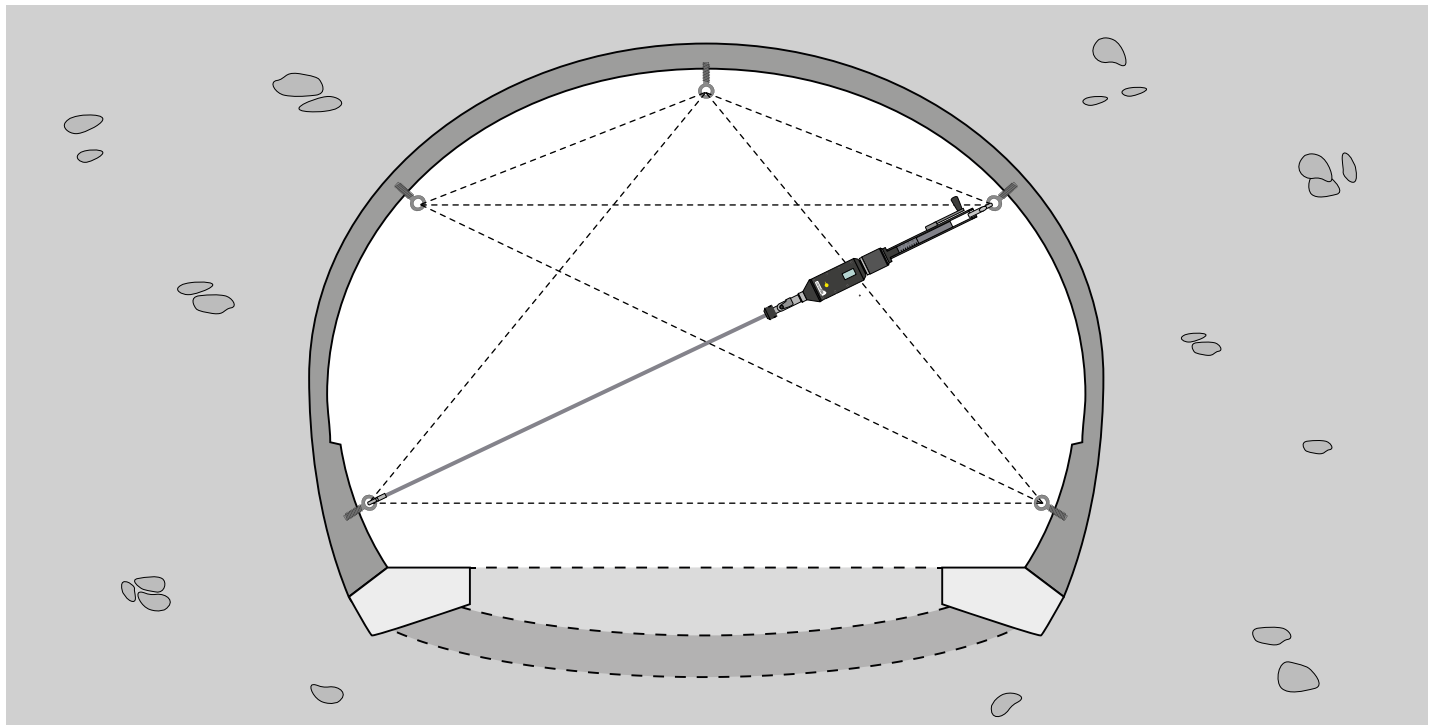

ACCESSORIES AND SPARE PARTS

THREADED HEAD BOLTS ODNOCH00000

Threaded reference bolts consist of a 3/8" stainless steel head mounted on a galvanized rebar (Ø 22 mm) or on an expansion anchor (Ø 14 mm). Available in 50 mm or 200 mm length. Supplied with protective plastic cap.



REFERENCE EYE BOLTS ODNOCH00E00

Eye bolts are composed by a galvanized rebar (Ø 22 mm) or on an expansion anchor (Ø 14 mm) with a loop at the end. Available in 50 mm or 200 mm length.



SPARE 30 METER TAPE ODNOOST3000

Spare stainless steel tape, 30 m length.

All the information in this document is the property of Sisgeo S.r.l. and should not be used without permission from Sisgeo S.r.l. We reserve the right to change our products without prior notice. The datasheet is issued in English and other languages. In order to avoid discrepancies and disagreement on the interpretation of the meanings, Sisgeo Srl declares that English Language prevails.

SISGEO S.R.L.

VIA F. SERPERO 4/F1
20060 MASATE (MI) ITALY
PHONE +39 02 95764130
FAX +39 02 95762011
INFO@SISGEO.COM

TECHNICAL ASSISTANCE

SISGEO offers customers e-mail and phone assistance to ensure proper use of instruments and readout and to maximize performance of the system.

For more information, email us: assistance@sisgeo.com